

April 13, 1948.

T. J. HERMES

2,439,733

MUTE FOR MUSICAL INSTRUMENTS

Filed Nov. 21, 1945

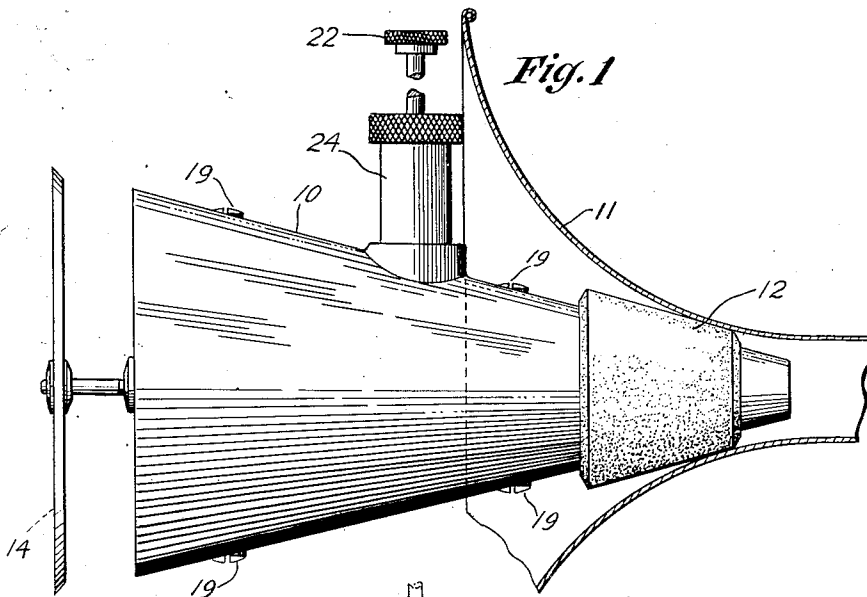

Fig. 1

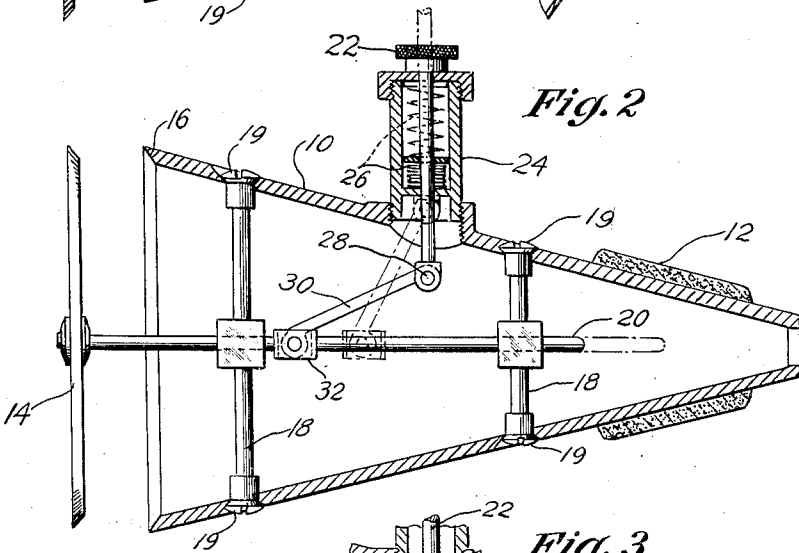

Fig. 2

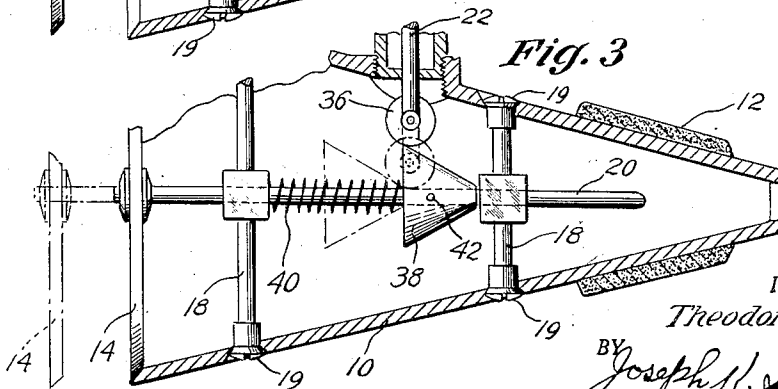

Fig. 3

INVENTOR.

Theodore J. Hermes

BY Joseph H. Schofield

ATTORNEY

UNITED STATES PATENT OFFICE

2,439,733

MUTE FOR MUSICAL INSTRUMENTS

Theodore J. Hermes, Stonington, Conn.

Application November 21, 1945, Serial No. 629,988

2 Claims. (Cl. 84-400)

1

This invention relates to mutes for musical instruments such as horns, etc., and particularly to a mute the tone-muting effect of which may be widely varied by the musician while the instrument is being played.

An object of the present invention is to provide a mute insertable within the bell of a musical instrument of the horn type, there being a valve member at the outer end of the mute which may be manually operated to control the amount of sound-diminishing effect of the mute during playing as required by the score.

Another object of the invention is to provide a conical member retained in the bell of a horn in a conventional manner and which in its normal position will effect maximum muting of the sounds given out by the instrument being played, but while playing of the instrument the amount of muting may be widely varied by the musician and more or less of the sound allowed to issue.

Another object of the invention is to enable tone effects to be modulated as to volume during the playing of single notes or passages by operation by the player of a single finger key.

With the above and other objects in view, the invention may include the features of construction and operation set forth in the following specification and illustrated in the accompanying drawing.

In the accompanying drawing annexed hereto and forming a part of this specification, I have shown the invention embodied in a mute for a trumpet but it will be understood that the invention can be otherwise embodied and that the drawing is not to be construed as defining or limiting the scope of the invention, the claims appended to this specification being relied upon for that purpose.

In the drawing:

Figure 1 is an outside view of a complete mute for a trumpet made in accordance with the present invention.

Fig. 2 is a longitudinal sectional view of the form of the invention shown in Fig. 1, and

Fig. 3 is a view similar to Fig. 2 partially broken away and showing a modified form of the invention.

In the above-mentioned drawings there have been shown but two embodiments of the invention which are now deemed preferable, but it is to be understood that changes and modifications may be made within the scope of the appended claims without departing from the spirit of the invention.

Briefly, and in its preferred aspect, the inven-

2

tion may include the following principal parts: First, a conical member having one or more resilient members on its surface fitting the bell of a horn or other instrument and frictionally retaining the mute in position within the bell; second, a valve member at the large end of the cone movable directly toward and from the cone; third, guiding means for the valve member within the mute during its movement from open to closed position; and fourth, operating means extending laterally from the cone and terminating in a finger key the depressing of which against the pressure of a light spring varies the volume of sound emitted by the horn.

Referring more in detail to the figures of the drawing, there is shown a hollow conical member 10 that may be made of metal, wood, plastic or other material having strips or an annular portion of cork 12 or other resilient material on the outer surface of the cone. The position of this resilient material 12 is such that it may engage the inner surface of the bell 11 of the horn and frictionally retain the mute in position therein. It will be understood that this material 12 and its position will be varied with the different types of horns with which the mute is to be used.

At the outer or larger end of the conical member 10 is a valve member 14 adapted to completely close the open end of the cone 10. Preferably and as shown in the figures, the conical member 10 is formed with a bevelled surface 16 forming a seat against which the bevelled periphery of the valve member 14 may fit.

To support the valve member 14 and guide it during its movement from closed to its maximum open position, the following means are provided. Within the conical member 10 are disposed transverse posts 18 retained in position by suitable fastenings 19 and having transverse openings in alinement with the axis of the cone 10. Attached to the valve member 14 and extending through these holes in the posts 18 is a guide rod 20, movement axially of which serves to open and close the valve member 14.

Operating means for the valve member 14 comprise a hand or finger depressed key 22 slidably mounted in a tubular projection 24 on one side of the conical member 10. A coiled spring 26 within the projection 24 normally holds the finger key 22 in its outer position which corresponds to that in which the valve member 14 is in its closed or muting position. At the inner end of the finger key 22 is a pivotal joint 28 for a short connecting rod 30 having a pivotal connection to a cross-head 32 forming a part of or fastened to

the guide rod 20. By depressing the finger key 22, therefore, the guide rod 20 is moved to the left as seen in the figures and the valve member 14 is moved toward its open or full tone position. With the finger key 22 fully depressed, the valve member 14 is moved to a position to very materially reduce the muting effect of the conical member 10. With pressure released from the finger key 22, the valve member 14 is returned to its closed or maximum muting position. By depressing the finger key 22 to intermediate positions, the muting effect may be quickly varied over a wide range, as during the playing of a single note.

Referring to Fig. 3, it will be seen that a modified form of operating means is provided. The finger key 22 at its inner end is provided with a freely rotating roller 36. In engagement with this roller 36 is a cone 38 on the guide rod 20 for the valve member 14. A spring 40 is disposed between one of the posts 18 for supporting the guide rod 20 and the face of the large end of the cone. The small end of the cone 38 clears the opposite post 18 so that the valve member 14 can seat firmly against the outer end of the conical member 10. To secure the cone 38 in fixed axial position on the guide rod 20, a cross pin 42 or other suitable fastening may be used.

I claim:

1. A mute for musical instruments comprising a generally conical member adapted to fit within the bell of a musical instrument, a disk-like valve member fitting within the outer end of said conical member, resilient means normally holding said valve in a position to close the outer end of said conical member, means within said conical member for supporting said valve for movement into and out of closed position and manual means to open and close said valve com-

prising a finger key movable in a direction normal to the direction of movement of the valve, supporting means for said finger key extending laterally from the side of said conical member, and means connecting said finger key and valve supporting means, whereby depressing said key will open said valve.

2. A mute for musical instruments comprising a generally conical member adapted to fit within the bell of a musical instrument, a disk-like valve member fitting within the outer end of said conical member, resilient means normally holding said valve in a position to close the outer end of said conical member, means within said conical member for supporting said valve for movement into and out of closed position, and manual means to open and close said valve, comprising a finger key movable in a direction normal to the direction of movement of the valve, supporting means for said finger key extending laterally from the side of said conical member at an intermediate point of the conical member and beyond the bell of said instrument, and means connecting said finger key and valve supporting means whereby depressing said key will open said valve.

THEODORE J. HERMES.

REFERENCES CITED

The following references are of record in the file of this patent:

UNITED STATES PATENTS

Number	Name	Date
1,387,490	Humes	Aug. 16, 1921
1,430,175	Mazzeri	Sept. 26, 1922
2,108,769	Humes	Feb. 15, 1938